

**HARDY
FLOOR SCALES**

**OPERATION AND INSTALLATION
MANUAL**

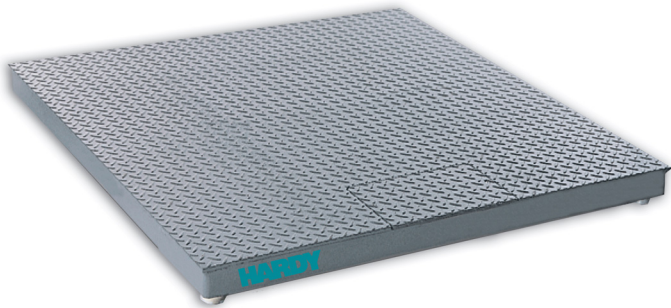

Corporate Headquarters

9440 Carroll Park Drive

San Diego, CA 92121

Phone: (858) 278-2900

FAX: (858) 278-6700

Email: hardyinfo@hardysolutions.com

Web-Site: <https://www.hardysolutions.com>

Hardy Process Solutions Doc. Number: 0596-0335-01 Rev D
Copyright 2014-2020 Hardy Process Solutions. All Rights Reserved. Printed in the U.S.A.

Local Field Service

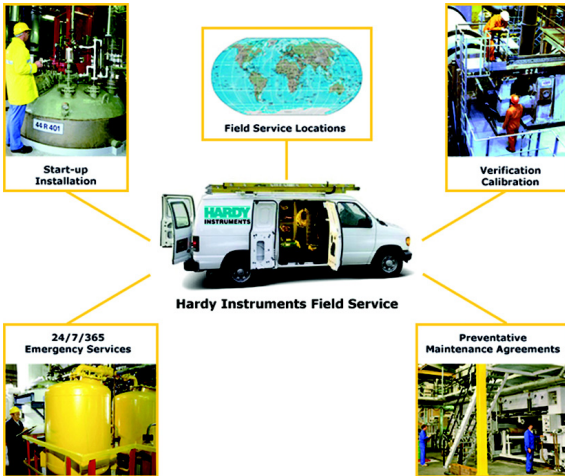

Hardy has over 200 field technicians in the U.S., and more positioned throughout the world to assist you in your support needs. We also have factory engineers who will travel to your facility anywhere in the world to help you solve challenging applications. We're ready to support you with:

- **Installation and start-up**
- **Routine maintenance and certification**
- **Plant audits and performance measurement**
- **Emergency troubleshooting and repair**

To request Emergency Service and Troubleshooting, Start-up, Installation, Calibration, Verification or to discuss a Maintenance Agreement please call **800-821-5831** or Emergency Service after hours (Standard Hours 6:30 AM to 5:30 PM Pacific Standard Time) and weekends.

Outside the U.S

Hardy Process Solutions has built a network of support throughout the globe. For specific field service options available in your area please contact your local sales agent or our U.S. factory at +1 **858-292-2710**.

CAUTION:

UNPACK WITH CARE

WHEN UNPACKING, DO NOT DISCARD THE PACKING CASE OR ANY PACKING MATERIAL, UNTIL THE CONTENTS OF THE PACKING CASE ARE INSPECTED AND CAREFULLY COMPARED WITH THE SHIPPING DOCUMENTS.

IF ANYTHING IS UNSATISFACTORY, PLEASE NOTIFY HARDY PROCESS SOLUTIONS IMMEDIATELY BY CALLING, FAXING OR E-MAILING US AT:

Hardy Service Center
Hardy Process Solutions
9440 Carroll Park Drive
San Diego, California 92121

Phone: (800) 821-5831
(858) 278-2900
FAX:(858) 278-6700

E-mail: hardysupport@hardysolutions.com
Web Address: www.hardysolutions.com

TO RETURN DEFECTIVE OR DAMAGED PRODUCT(S) CALL HARDY TECHNICAL SUPPORT FOR A HARDY SERVICE TICKET NUMBER (HST#). YOUR COMPANY NAME, ADDRESS, TELEPHONE NUMBER, SERIAL NUMBER OF THE UNIT AND A BRIEF DESCRIPTION OF THE PROBLEM SHOULD BE READY WHEN CALLING. FOR ALL NON-WARRANTY REPAIRS A PURCHASE ORDER OR CREDIT CARD IS ALSO REQUIRED.

IN CASE OF DAMAGE DUE TO SHIPPING, NOTIFY THE DELIVERING CARRIER IMMEDIATELY FOR AN INSPECTION.

Table of Contents

Table of Contents - - - - -	- i
INTRODUCTION - - - - -	- 1
SPECIFICATIONS - - - - -	- 1
Platform Material - - - - -	- 1
Platform Height ¹	
Rated Output - - - - -	- 1
Capacities - - - - -	- 1
Excitation- - - - -	- 2
Load Points - - - - -	- 2
Total Error - - - - -	- 2
Maximum Overload- - - - -	- 2
End Loading - - - - -	- 2
HI 6011 Summing Box Power Rating - - - - -	- 2
Certifications - - - - -	- 2
Temperature Range - - - - -	- 3
Temperature Effect - - - - -	- 3
Cable Length - - - - -	- 3
Materials of Construction - - - - -	- 3
Steel - - - - -	- 3
Paint - - - - -	- 3
Foot Elastomer - - - - -	- 3
Grade Level - - - - -	- 3
Accessories - - - - -	- 3
Anchor Bolt Holds - - - - -	- 3
NEMA Rating- - - - -	- 3
Test Criteria - - - - -	- 4
UNPACKING - - - - -	- 4
COMPONENT DESCRIPTIONS - - - - -	- 5
SITE PREPARATION- - - - -	- 6
Precautions - - - - -	- 7
FLOOR SCALE INSTALLATION - - - - -	- 8
CALIBRATION - - - - -	- 11

Hardy Floor Scales

Pre-Calibration Procedures - - - - -	-11
C2® Second Generation Calibration - - - - -	-12
Test Weight Calibration (Hard Cal) - - - - -	-12
Requirements: - - - - -	-12
Material Substitution: - - - - -	-13
SCALE VERIFICATION - - - - -	-13
MODEL CODE BREAKDOWN - - - - -	-14
Carbon Steel Deck, Painted- - - - -	-14
Stainless Steel Deck (304 SS) - - - - -	-15
REMOVING SUMMING BOX COVER- - - - -	-17
Installing the Leveling Feet - - - - -	-19
INSTALLING A LOAD SENSOR - - - - -	-21
OPTIONAL PIT FRAMES - - - - -	-25
About Pit Frames - - - - -	-25
OPTIONAL PORTABILITY KIT - - - - -	-30
OPTIONAL ACCESS RAMPS- - - - -	-30
Access Ramp Installation - - - - -	-30
OPTIONAL FOOT RETAINER - - - - -	-33
Foot Retainer Plates Installation- - - - -	-33
OPTIONAL BUMPER GUARDS- - - - -	-34
Installing Bumper Guards - - - - -	-34
OPTIONAL INDICATOR COLUMN - - - - -	-36
TROUBLESHOOTING - - - - -	-36
Problem: - - - - -	-36
Cause #1: - - - - -	-36
Cause #2: - - - - -	-36
Cause #3: - - - - -	-36
Remedies: - - - - -	-36
Problem: - - - - -	-37
Cause #1: - - - - -	-37
Remedy #1: - - - - -	-37
Cause #2: - - - - -	-37

Table of Contents

Remedy #2: - - - - -37
Problem: - - - - -37
Cause #1: - - - - -37
Remedy #1: - - - - -37
Cause#2:- - - - -37
Remedy #2: - - - - -37
Cause #3: - - - - -38
Remedy #3: - - - - -38
Cause #4: - - - - -38
Remedy #4: - - - - -38

INSTRUMENTATION INTERFACE CABLE COLOR CODES - - - - -38

Hardy Floor Scales

TABLE OF CONTENTS - - - - - **-I**

INSTALLING THE CLOSED EYEBOLTS INTO THE TOP PLATE - - - -5

HI 6011 SUMMING JUNCTION CARD - - - - -6

WHEN DRIVING HEAVY EQUIPMENT ON AND OFF SCALE- - - -8

MAXIMUM HEIGHT - - - - -8

SPIRIT LEVEL - - - - -9

CHECKING PLATFORM LEVEL/SIDE TO SIDE- - - - -9

CHECKING PLATFORM LEVEL/CORNER TO CORNER - - - - -10

CHECKING PLATFORM LEVEL/DIAGONALLY - - - - -10

ADJUSTING THE FEET FOR LEVEL - - - - -11

SCALE VERIFICATION/POSITION #3 - - - - -13

REMOVING THE SUMMING BOX COVER - - - - -17

REMOVING THE SUMMING BOX LID - - - - -18

A HARDY HI 6011 SUMMING BOX WITH THE LID REMOVED
(WITHOUT LOAD CELL CABLING)- - - - -18

INSERTING THE LEVELING FOOT INTO THE LOAD SENSOR- - - -19

INSIDE VIEW- - - - -20

OUTSIDE VIEW - - - - -20

ALL FOUR FEET INSTALLED - - - - -21

SUMMING CARD- - - - -21

CABLE GLAND- - - - -23

REMOVING LOAD SENSOR BOLTS AND FEET - - - - -24

FOUNDATION FOR THE PIT FRAME - - - - -26

PIT FRAME DIMENSIONS - - - - -27

DRAIN INSTALLATION DIMENSIONS - - - - -28

EXCAVATED PIT AND SUPPORT FOR THE PIT FRAME- - - - -29

RAMP WITH RETAINER PLATES - - - - -31

INSTALLING ANCHORS FOR RAMP- - - - -32

FOOT RETAINER PLATES - - - - -33

INSTALLATION - - - - -33

BUMPER GUARD/GAP REQUIREMENT - - - - -35

BUMPER GUARD/INSTALLATION - - - - -35

Hardy Floor Scales

INTRODUCTION

Hardy Floor Scales are designed for applications that require a low profile weighing surface with high commercial accuracy and reliability. These durable wash-down scales can be used in hazardous areas with the appropriate barriers. The Hardy Floor Scales can be configured with a complete range of accessories. Rugged Hardy Floor Scales are rated for 250,000 load cycles under normal loading conditions.* They can be sized or configured to fit any floor scale application.

*Contact Hardy for more information

The typical platform height is 3.375 inches (8.6 cm). Each corner can be adjusted an additional .275" (7mm) to compensate for a non-level floor or pit mounting surface.

Hardy Floor Scales do not have bearings, levels or moving parts that can be damaged or wear out. The active elements of the floor scales are four precision Hardy load sensors, mounted in all four corners of the scale platform with an integrated HI 6011 junction box. The unique Blind Hole Load Introduction technology allows the foot to move to compensate for uneven floors. This ensures that the load forces are always applied to the load sensor at precisely the same point regardless of where the load is placed on the scale. This ensures you will get accurate and repeatable weighments.

Each platform load sensor is initially certified for use in a C2[®] Second Generation Calibration system.

SPECIFICATIONS

Platform Material	0.25 inch painted carbon steel or stainless steel.
Platform Height	3.375 inches (8.6 cm) deck height adjustable 0.275" (7mm)
Rated Output	2.0mV/V ±0.1%
Capacities	Available in eight sizes from 30 x 30 inch to 6 x 8 feet in 1, 2.5, 5, and 10 thousand pound capacities

Hardy Floor Scales

Excitation

- Recommended 5 Volts DC
- Maximum 5 Volts DC

WARNING

FOR SCALES FITTED WITH AN INTEGRATED TECHNICIAN SUMMING CARD, DO NOT EXCEED 5 VDC EXCITATION. DOING SO MAY CAUSE PROPERTY DAMAGE. DO NOT USE WITH ANY INSTRUMENT WITH AN EXCITATION VOLTAGE ABOVE 5 VDC.

Load Points

- HARDY ADVANTAGE® Load Sensors
- Factory Matched
 - Stainless Steel
 - True Hermetic Seal
 - No Cornering

Total Error

0.03% of FS Output

Maximum Overload

100% of the Rated Scale Capacity

End Loading

100% of the Rated Scale Capacity

HI 6011 Summing Box Power Rating

5 VDC, Class 2 source, max. 50 mA

For Class I and II, Division 1 Hazardous (Classified) Locations, and Class 1, Zone 0 and 2 Groups IIC, Zone 20 and 22 Groups IIIC, power must be supplied to the summing box through approved intrinsically safe barriers per control drawing 0594-0010. (Available for download on the Hardy Floor Scales webpage under Docs & Programs).

Certifications

- UL, CUL, CE
- RoHS3 and REACH Compliant
- **Hazardous Areas:** Class I, Division 1, Groups A, B, C, D, T4; Zone 0, Group IIC, T4; Division 2, Groups A, B, C, D, T5
- Class II, Division 1, Groups E, F, G, T4; Zone 20, Group IIIC; Division 2, Groups F, G, T5
- Class III, Division 1, T4; Division 2, T5

Temperature Range	<ul style="list-style-type: none">• Operating -40° to +80° Degrees C (-40° to +176° F)• Ambient -10 to +40 Degrees C (+14° to 104° Degrees F)
Temperature Effect	<ul style="list-style-type: none">• On Output - 0.0011% of load/Deg. C• On Zero - 0.0011% of FSO/Deg C
Cable Length	20 feet C2 Cable (6.096 meters)

NOTE: *To purchase additional C2 Cable, contact our local Hardy Process Solutions Representative or Hardy Service Center.*

Materials of Construction

- | | |
|--------------|---|
| Steel | <ul style="list-style-type: none">• Carbon Steel: Type A36 carbon plate steel (slip resistance - tread or smooth surface)• Stainless Steel: Type 304 plate steel (slip resistance - tread or smooth surface) |
|--------------|---|

Paint	Two-part UV resistant Polyurethane - 2 to 4 mil top coat - Carbon Steel only. Note: Stainless Steel scales are not painted)
--------------	--

- | | |
|-----------------------|---|
| Foot Elastomer | <ul style="list-style-type: none">• Natural Rubber (Standard) |
|-----------------------|---|

Grade Level	In operation, the scale must be firmly and adequately supported at all four corners to accommodate the maximum load in your application. The scale must be installed to within 3° of level.
--------------------	---

Accessories	Ramps, Pit Frames, Bumper Guards, Lift Decks, Lifting Eye Bolts, Bolt Down Plates
--------------------	---

Anchor Bolt Holds	1/2 inch bolts - 9/16" (.5625") hole, 3.75 inches deep 5/8 inch bolts - 5/8" (.6250") hole, 4.0 inches deep •
--------------------------	---

NEMA Rating	Summing Junction Box Enclosure - NEMA 4 Stainless Steel
--------------------	---

Hardy Floor Scales

Test Criteria

Must exclude at least 65 GPM of water from 1” inch nozzle delivered from a distance not less than 10 ft for 5 minutes.

UNPACKING

Hardy Floor Scales are shipped fully assembled and wired. Inspect the container for any signs of damage that might occur during shipment. Since almost all of the Floor Scales are shipped F.O.B. factory, such damage is normally the responsibility of the carrier and should be reported to them.

Step 1. Remove the banding straps and any shipping restraints.

WARNING

DO NOT USE HOOKS OR UNCLOSED EYE-BOLTS OR ATTEMPT TO LIFT THE SCALE MANUALLY. FAILURE TO USE THE PROPER LIFTING TOOLS OR LIFTING METHODS CAN CAUSE PERSONAL INJURY OR PROPERTY DAMAGE.

Step 2. Screw 2 closed eye bolts into the threaded holes on the top plate of the scale. (See Fig. 1)

- Mild Steel - 1/2 - 13 x 1.5” (Hardy Model Number HIFSEB-PS)

Step 3. Attach a chain, cable or nylon strap to the eyebolts.

Step 4. Use a forklift or crane with rated lifting capacity that is equal to or greater than the total weight of the platform scale to lift the scale high enough to remove from the crate bottom. See Tables 2 & 3 for shipping weights.

Step 5. Be sure to use all safety precautions when lifting the platform so that it does not fall on equipment or personnel. It is highly recommended that blocks be placed under the platform before working near the platform scale.

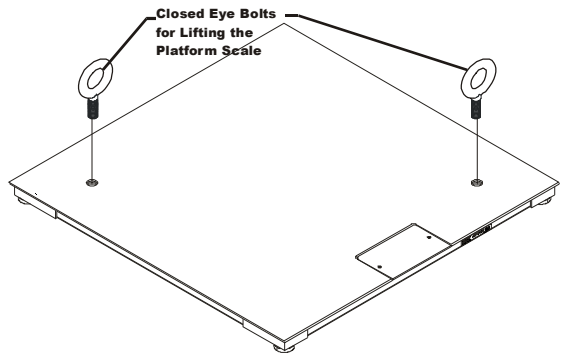

FIG. 1 INSTALLING THE CLOSED EYE-BOLTS INTO THE TOP PLATE

COMPONENT DESCRIPTIONS

1. **Steel Plate Platform** - The platform material is either painted carbon steel or 304 stainless steel. The carbon steel platform cover is made from a single piece of 1/4" A36 carbon steel floor plate (skid resistant) or smooth steel plate. The steel platforms are primed and coated with a tough weather resistant paint (See Paint Specifications). The 304 stainless steel platform is made from a single piece of 1/4" diamond tread (Conforms to ASTM A793-85) floor plate (skid resistant) or smooth stainless steel plate with a bead blast finish.
2. **Summing Junction Card Assembly** - Accessed by unfastening the 2 screws on the deck plate on the center side of the platform. (See Fig.2) The summing junction card routes the excitation voltage to each of the four load sensors and sums the weight signal back from them. The C2[®] second generation electronic calibration is included with your scale.

For Class I and II, Division 1 Hazardous (Classified) Locations, and Class 1, Zone 0 and 2 Groups IIC, Zone 20 and 22 Groups IIIC, power must be supplied to the Summing Box through approved intrinsically safe barriers per control

drawing 0594-0010. (Available for download on the Hardy Floor Scales webpage under Docs & Programs).

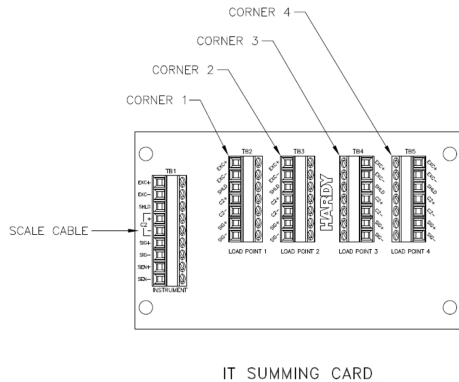

FIG. 2 HI 6011 SUMMING JUNCTION CARD

3. **Load Sensors** - The Hardy series scales use four (4) steel Advantage[®] load sensors with hermetic seals. The output of each sensor is 2mV/V with 5 Volts DC excitation. For more specifications see the electrical specification section of this manual.
4. **INTEGRATED TECHNICIAN™** - A built-in system diagnostics utility, continuously monitors the weighing system for possible malfunctions. This capability also allows the operator to rapidly troubleshoot a weighing system from the controller or indicator.
5. **Leveling Feet** - Each Hardy series scale comes with four (4) 304 stainless steel adjustable leveling feet. The leveling feet are adjustable to a maximum of 7mm (.275"). The leveling feet are attached to each of the load sensors.

SITE PREPARATION

- All mounting surfaces for the floor scale should be level to within 3°, corner to corner, end to end. Keep in mind that the adjustable leveling feet have a maximum adjustment of 7mm (.275").

- For Class I and II, Division 1 Hazardous (Classified) Locations, and Class 1, Zone 0 and 2 Groups IIC, Zone 20 and 22 Groups IIIC, power must be supplied to the Summing Box through approved intrinsically safe barriers per control drawing 0594-0010. (Available for download on the Hardy Floor Scales webpage under Docs & Programs).
- Before welding anything on the floor scale, contact Hardy Process Solutions Service Center for instructions and precautions.
- Proper drainage must be provided to prevent the load sensors from standing in water.

Precautions

- Do not do any electric welding on or near the platform scale.
- Do not drop items to be weighed on the scale. Set them carefully on the platform scale.
- Do not set items on the platform scale that weigh more than the capacity of the scale.
- Do not store or operate the scale in environments out of the specified temperature range.
- Do not store other equipment on the scale even temporarily when it is not used or in storage.
- Do not allow debris to accumulate on, around or under the scale.
- Do not set the scale in water or allow water to accumulate around the scale. Always provide proper drainage.
- Do not let moisture get on or into any of the electrical interconnections.
- Do not allow static or other electrical discharges go through the scale.
- Do not leave the screws for the summing junction box cover plate loose so that the junction box is not sealed.
- Do not drop the scale when moving or installing.
- When driving heavy equipment on and off the scale for weighing purposes, make sure that you drive onto and off of the platform in

Hardy Floor Scales

the direction indicated in Figure 3. Also See Access Ramp Installation Section.

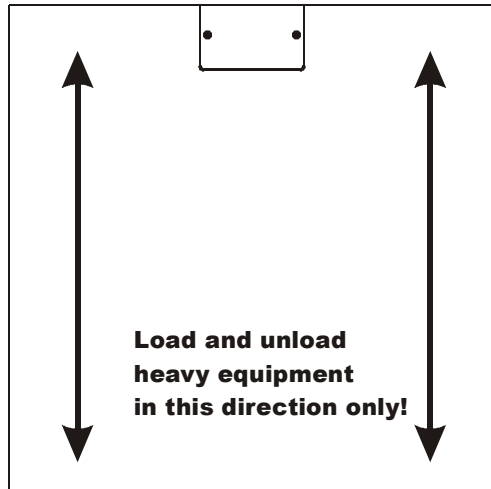

FIG. 3 DIRECTION WHEN DRIVING HEAVY EQUIPMENT ON AND OFF THE SCALE

FLOOR SCALE INSTALLATION

- Step 1. Place the platform scale on the operating location. Make sure that the platform height is within 3 to 3.275" as measured from the top of the cover plate to the top of the floor surface. (See Fig. 4)

NOTE:

With the scale in place, the clearance around the edge of the platform and pit coping should be 1/4" to 3/8".

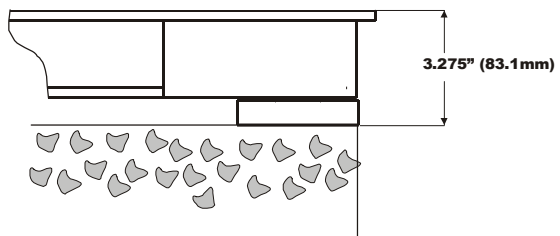

FIG. 4 MAXIMUM HEIGHT

- Step 2. Make sure that the platform mounting surface is level to 1/8".
- Step 3. Use a level (Spirit level, Bullseye level or similar) to check if the platform is level, side to side, corner to corner and diagonally. (See Figs. 9, 10, 11, 12)

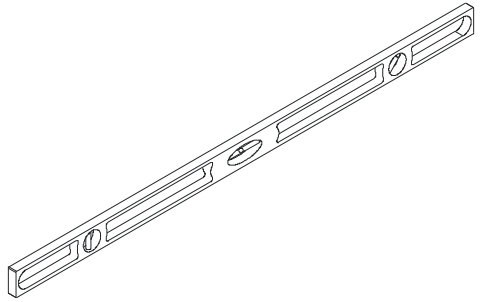

FIG. 5 SPIRIT LEVEL

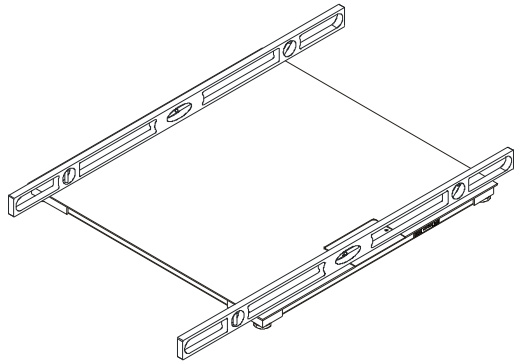

FIG. 6 CHECKING PLATFORM LEVEL/SIDE TO SIDE

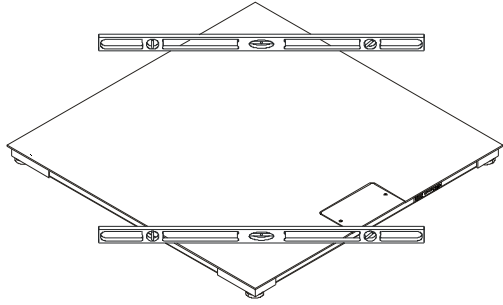

FIG. 7 CHECKING PLATFORM LEVEL/CORNER TO CORNER

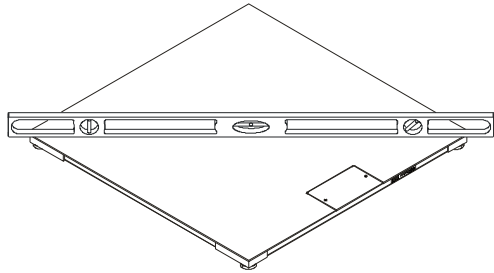

FIG. 8 CHECKING PLATFORM LEVEL/DIAGONALLY

Step 4. Adjust each of the leveling feet in the direction (either up or down), indicated by the level readings. (See Fig. 9)

- To increase the height rotate the foot counter clockwise.
- To decrease the height rotate the foot clockwise.

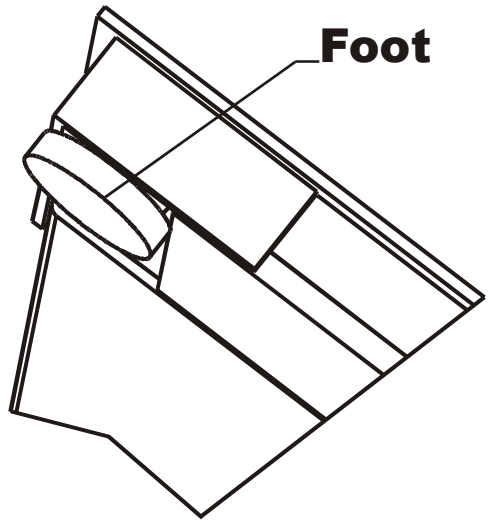

FIG. 9 ADJUSTING THE FEET FOR LEVEL

- Step 5. Place the spirit level on the platform surface again to check the adjustment for level. Keep adjusting the legs until the platform is level and all four leveling feet are firmly on the floor surface.
- Step 6. Check the distance from the top of the platform to the floor surface at each corner. All the measurements should be within 3° of each other and the platform should be level.
- Step 7. If the installation requires bolt down plates to keep the floor scale in place go to the Optional Bolt Down Plates Section for instructions.

CALIBRATION

Pre-Calibration Procedures

- Step 1. Open the Junction box cover. (See Fig. 11 for Instructions)
- Step 2. Thread the C2[®] Certified cable through the grommet on the side of the scale that houses the junction box.

Hardy Floor Scales

Step 3. Connect the C2 Certified Summing Card Interface Cable to the weight instrument. Color code wires as follows:

- + Excitation Red
- + Sense Blue
- + Signal Green
- - Signal White
- - Sense Brown
- - Excitation Black
- + C2 Grey
- - C2 Violet

Step 4. Use the weight instrument/indicator manual for calibration instructions.

NOTE:

To purchase C2[®] certified cable, contact your local Hardy Representative or the Hardy Process Solutions Service Center.

C2[®] Second Generation Calibration

Definition - C2[®] electronically calibrates a scale system without the need for test weights. This feature is built into all Hardy weight or rate controllers, and in the Hardy weight modules for Rockwell PLCs.

Step 1. Refer to the Hardy weight or rate controller or the Rockwell PLC module manual for complete calibration instructions.

Test Weight Calibration (Hard Cal)

Requirements:

- Test weight calibration requires the use of certified class 'F' test weights equal to a minimum of 80% of the rated scale capacity.
- Three weights between 10% and 100% of the scale capacity should be used to check the mid range.
- Several low capacity weights equivalent to one or two instrument divisions are required to check the systems' sensitivity.

Material Substitution:

- When certified test weights are not available you can use an accurately weighed material instead.
- The material must be weighed on a secondary, calibrated scale and delivered to the site of the primary floor scale for calibration.
- The secondary calibrated scale should be of the same accuracy or greater and have a capacity approximately equal to the primary floor scale.

SCALE VERIFICATION

- Step 1. Get a test weight that is equal to 10% of the full scale capacity.
- Step 2. Place the test weight at Position #1 on the platform. (See Fig. 10)

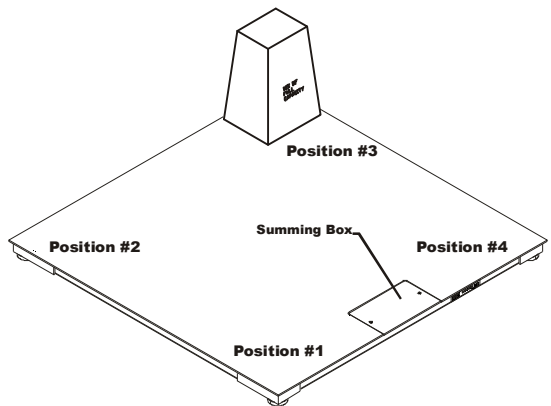

FIG. 10 SCALE VERIFICATION/POSITION #3

- Step 3. Write down the weight for position #1.
- Step 4. Place the weight at position #2.
- Step 5. Write down the weight for position #2.
- Step 6. Place the weight at position #3.
- Step 7. Write down the weight for position #3.
- Step 8. Place the weight at position #4.
- Step 9. Write down the weight for position #4.
- Step 10. Check all the readings. If all the readings are within an acceptable tolerance, no re-calibration is required.

Hardy Floor Scales

Step 11. If all the readings are not within an acceptable tolerance contact the Hardy Process Solutions Service Center.

MODEL CODE BREAKDOWN

Carbon Steel Deck, Painted

Tread Plate Deck Painted	Smooth Plate Deck Painted	CAPACITY		Overall Size		Ship Wght
		LBS	KGS	Feet	CM	LBS (KGS)
HIFS-3030-01-PS-T	HIFS-3030-01-PS-S	1000	454	30" x 30"	76 x 76	200 (91)
HIFS-3030-02-PS-T	HIFS-3030-02-PS-S	2500	1000	30" x 30"	76 x 76	200 (91)
HIFS-3030-05-PS-T	HIFS-3030-05-PS-S	5000	2500	30" x 30"	76 x 76	200 (91)
HIFS-3636-01-PS-T	HIFS-3636-01-PS-S	1000	454	3' x 3'	91 x 91	250 (113)
HIFS-3636-02-PS-T	HIFS-3636-02-PS-S	2500	1134	3' x 3'	91 x 91	250 (113)
HIFS-4848-02-PS-T	HIFS-4848-02-PS-S	2500	1134	4' x 4'	122 x 122	405 (184)
HIFS-4848-05-PS-T	HIFS-4848-05-PS-S	5000	2268	4' x 4'	122 x 122	405 (184)
HIFS-4848-10-PS-T	HIFS-4848-10-PS-S	10000	4536	4' x 4'	122 x 122	405 (184)
HIFS-4860-05-PS-T	HIFS-4860-05-PS-S	5000	2268	4' x 5'	122 x 152	500 (227)
HIFS-4860-10-PS-T	HIFS-4860-10-PS-S	10000	4536	4' x 5'	122 x 152	500 (227)
HIFS-4872-05-PS-T	HIFS-4872-05-PS-S	5000	2268	4' x 6'	122 x 183	600 (272)
HIFS-4872-10-PS-T	HIFS-4872-10-PS-S	10000	4536	4' x 6'	122 x 183	600 (272)
HIFS-6060-05-PS-T	HIFS-6060-05-PS-S	5000	2268	5' x 5'	152 x 152	650 (295)

Table 1: Carbon Steel, Painted

Tread Plate Deck Painted	Smooth Plate Deck Painted	CAPACITY		Overall Size		Ship Wght
MODEL	MODEL	LBS	KGS	Feet	CM	LBS (KGS)
HIFS-6060-10-PS-T	HIFS-6060-10-PS-S	10000	4536	5' x 5'	152 x 152	650 (295)
HIFS-6084-05-PS-T	HIFS-6084-05-PS-S	5000	2268	5' x 7'	152 x 213	900 (408)
HIFS-6084-10-PS-T	HIFS-6084-10-PS-S	10000	4536	5' x 7'	152 x 213	900 (408)
HIFS-7296-10-PS-T	HIFS-7296-10-PS-S	10000	4536	6' x 8'	183 x 244	1150 (522)

Table 1: Carbon Steel, Painted**Stainless Steel Deck (304 SS)**

Tread Plate Stainless Steel Deck	Smooth Stainless Steel Deck	CAPACITY		Overall Size		Ship Wght
MODEL	MODEL	LBS	KGS	Feet	CM	LBS (KGS)
HIFS-3030-01-SS-T	HIFS-3030-01-SS-S	1000	454	30" x 30"	76 x 76	200 (91)
HIFS-3030-02-SS-T	HIFS-3030-02-SS-S	2500	1000	30" x 30"	76 x 76	200 (91)
HIFS-3030-05-SS-T	HIFS-3030-05-SS-S	5000	2500	30" x 30"	76 x 76	200 (91)
HIFS-3636-01-SS-T	HIFS-3636-01-SS-S	1000	454	3' x 3'	91 x 91	250 (113)
HIFS-3636-02-SS-T	HIFS-3636-02-SS-S	2500	1134	3' x 3'	91 x 91	250 (113)
HIFS-4848-02-SS-T	HIFS-4848-02-SS-S	2500	1134	4' x 4'	122 x 122	405 (184)
HIFS-4848-05-SS-T	HIFS-4848-05-SS-S	5000	2268	4' x 4'	122 x 122	405 (184)
HIFS-4848-10-SS-T	HIFS-4848-10-SS-S	10000	4536	4' x 4'	122 x 122	405 (184)

Table 2: Stainless Steel

Hardy Floor Scales

Tread Plate Stainless Steel Deck	Smooth Stainless Steel Deck	CAPACITY		Overall Size		Ship Wght
		MODEL	MODEL	LBS	KGS	Feet
HIFS-4860-05-SS-T	HIFS-4860-05-SS-S	5000	2268	4' x 4'	122 x 152	500 (227)
HIFS-4860-10-SS-T	HIFS-4860-10-SS-S	10000	4536	4' x 5'	122 x 152	500 (227)
HIFS-4872-05-SS-T	HIFS-4872-05-SS-S	5000	2268	4' x 6'	122 x 183	600 (272)
HIFS-4872-10-SS-T	HIFS-4872-10-SS-S	10000	4536	4' x 6'	122 x 183	600 (272)
HIFS-6060-05-SS-T	HIFS-6060-05-SS-S	5000	2268	5' x 5'	152 x 152	650 (295)
HIFS-6060-10-SS-T	HIFS-6060-10-SS-S	10000	4536	5' x 5'	152 x 152	650 (295)
HIFS-6084-05-SS-T	HIFS-6084-05-SS-S	5000	2268	5' x 7'	152 x 213	900 (408)
HIFS-6084-10-SS-T	HIFS-6084-10-SS-S	10000	4536	5' x 7'	152 x 213	900 (408)

Table 2: Stainless Steel

**REMOVING SUMMING
BOX COVER**

- Step 1. Use a Phillips screwdriver to remove the two flat head machine screws that fasten the summing box cover to the floor scale frame. (See Fig. 11)

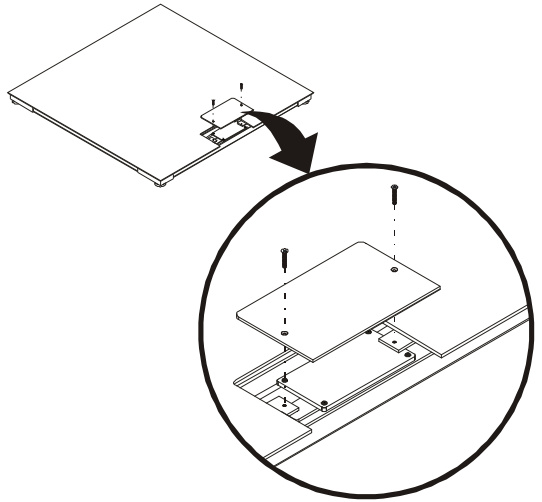

**FIG. 11 REMOVING THE SUMMING BOX
COVER**

- Step 2. Gently pull the frame cover out of the enclosure. You now have access to the summing junction box and C2 Certified Cable as shipped.
- Step 3. Remove the 8 hex head screws that fasten the cover to the summing box chassis using a 5.5mm hex wrench or a 5.5mm hex socket (See Fig. 12)

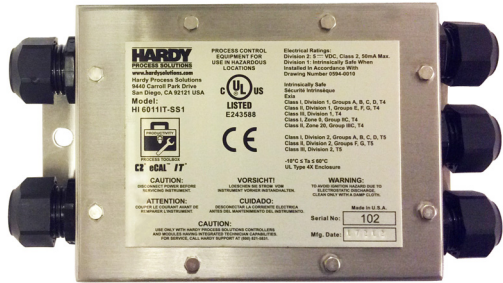

FIG. 12 REMOVING THE SUMMING BOX LID

Step 4. After removing the 8 hex bolts, carefully set them aside for reassembly (Step 17). You may now remove the lid from the junction box chassis so that you can see all the wiring from the load sensors and to the instrument/indicator. (See Fig. 13)

NOTE:

The HI 6011 Summing box is pre-wired and sealed. You should only remove the cover if you need access to the load cell cabling and only then if you are replacing a load cell.

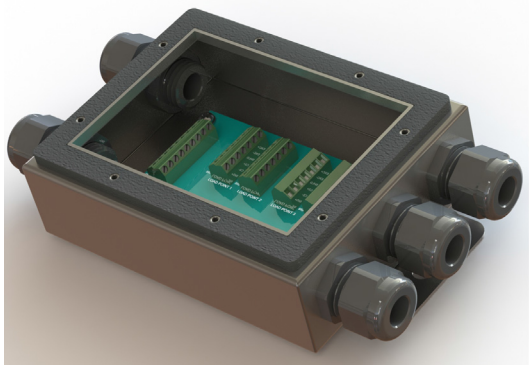

FIG. 13 A HARDY HI 6011 SUMMING BOX WITH THE LID REMOVED (WITHOUT LOAD CELL CABLING)

Installing the Leveling Feet

- Step 1. Remove the lock bolt and nut from the leveling foot.
- Step 2. With the scale raised and securely blocked, insert the leveling foot into the load sensor. Make sure the through hole in the foot is aligned with the bottom through hole on the load sensor. (See Fig. 14)

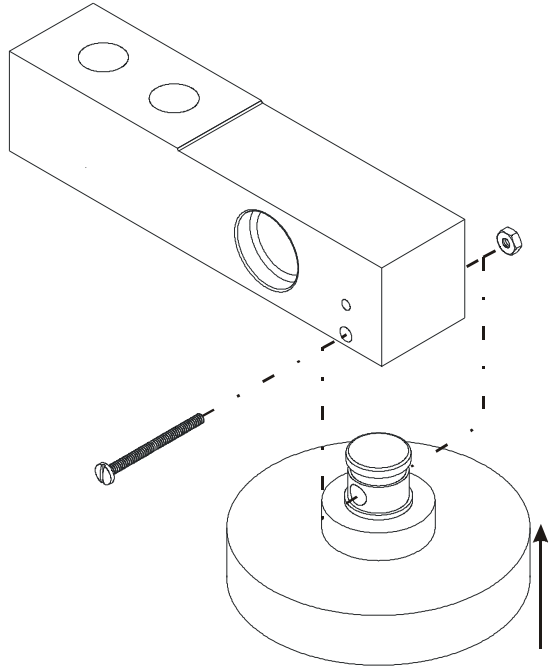

FIG. 14 INSERTING THE LEVELING FOOT INTO THE LOAD SENSOR

NOTE:

You may need to push with a little force due to some interference caused by the O-ring that is attached to the foot. DO NOT USE A HAMMER OR TRY TO DRIVE THE FOOT INTO THE HOUSING.

- Step 3. With the through holes aligned, insert the lock bolt going from the center of the scale outward. This eliminates having to remove

Hardy Floor Scales

the load sensors when installing the lock bolt.

- Step 4. Screw the nut onto the lock bolt until it is tight. The feet should look like the following: (See Figs. 15 & 16)

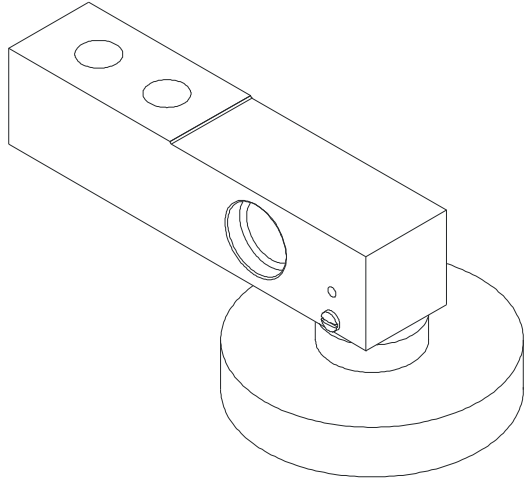

FIG. 15 INSIDE VIEW

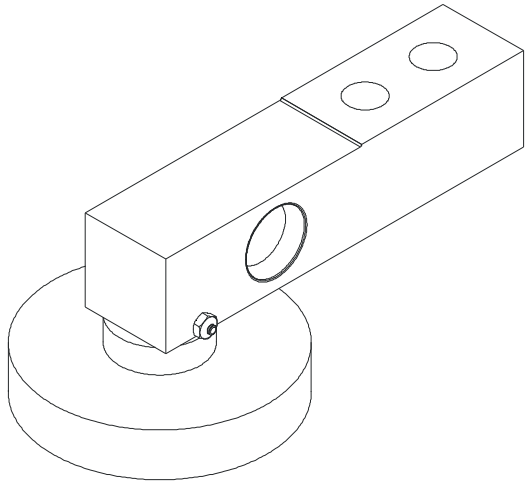

FIG. 16 OUTSIDE VIEW

Step 5. Install all four (4) feet. (See Fig. 17)

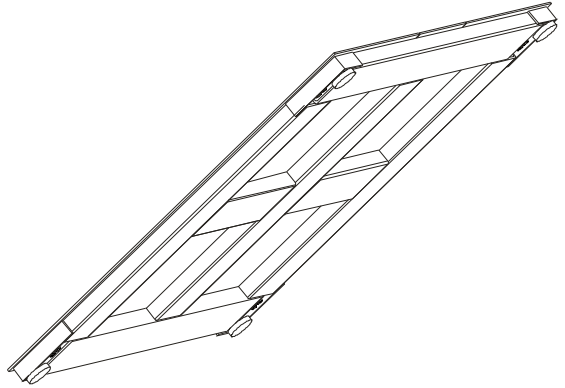

FIG. 17 ALL FOUR FEET INSTALLED

INSTALLING A LOAD SENSOR

Step 1. Shut all power off to the floor scale.
Step 2. To gain access to the Summing Card follow the instructions above (Steps 3-4 on pages 17 and 18). You do not have to remove the summing card or the bottom of the Junction box to install a new load sensor. (See Fig. 18)

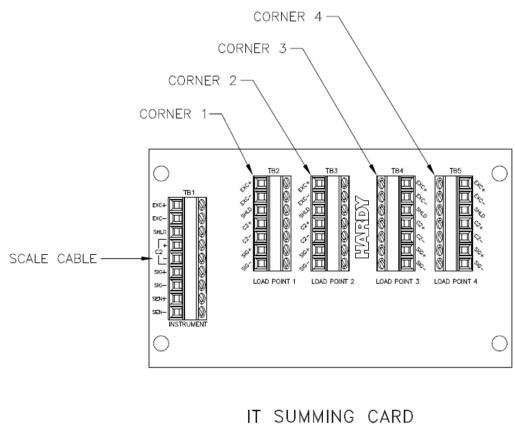

FIG. 18 SUMMING CARD

Hardy Floor Scales

Load Sensor #	Connector
Load Sensor #1	TB1
Load Sensor #2	TB2
Load Sensor #3	TB3
Load Sensor #4	TB4
To Instrument	TB5

Table 3: Summing Card Load Sensor Connectors

Step 3. Use a small slotted head screw driver and disconnect the Load Sensor cable. It is a good idea to mark the wires if the wire markers have been removed. Color code wires are as follows:

We recommend the use of C2 cable from the weighing instrument to the junction box. Note the color codes for C2 load points (left to right facing the rear panel). Match the load sensor's color coding to ease trouble shooting.

Load cell connector Rear panel 9 pin	C2 cable TB9 7 pin to Junction Box	Load cell color codes 3 pin connector
<ul style="list-style-type: none"> • Shield Ground Wire • C2- Violet • C2+ Grey • EXC- Black • SEN- Brown • SIG- White • SIG+ Green • SEN + BLUE • EXC+ RED 	<ul style="list-style-type: none"> • EXC- Black • SEN- Brown • EXC+ RED • SEN+ BLUE • Shield Ground Wire • C2+ Grey • C2- Violet • SIG+ Green • SIG- White 	<ul style="list-style-type: none"> • EXC+ RED • EXC- Black • Shield Ground Wire <p><u>4 pin connector</u></p> <ul style="list-style-type: none"> • C2+ Grey • C2- Violet • SIG+ Green • SIG- White

- Step 4. Loosen the cable gland nut for the load sensor cable you want to remove. (See Fig. 19)

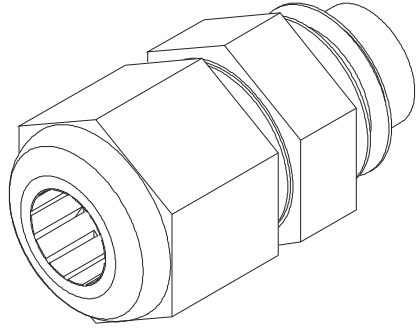

FIG. 19 CABLE GLAND

- Step 5. From the load sensor pull the cable out of the junction box and through the channel until all the cable has been removed.
- Step 6. Use the closed eye bolts and chain, cable or nylon strapping to lift the floor scale high enough to remove the load sensor or turn the scale completely over and let the top plate rest on blocks for easier access to the feet.
- Step 7. Block the floor scale adequately so that the platform will not drop on any machinery or personnel.
- Step 8. Remove the lock bolt on the load sensor foot you are removing. Store in a safe place so that you don't forget to install it.
- Step 9. Pull the load sensor leveling foot out of the load sensor.
- Step 10. Use a socket wrench and remove the two bolts that fasten the load sensor to the mount.
- Step 11. Lift the load sensor out of the housing.

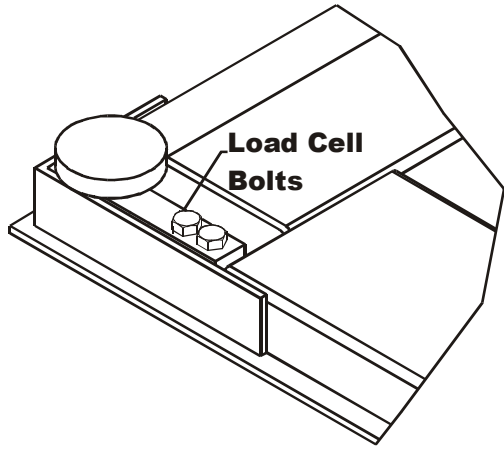

FIG. 20 REMOVING LOAD SENSOR BOLTS AND FEET

- Step 12. Place the new load sensor so that the through bolt holes are aligned with the threaded mounting holes and in the same direction as the old load sensor. **DO NOT CUT OR REUSE THE OLD CABLE ON THE NEW LOAD SENSOR.**
- Step 13. Screw in the two (2) load sensor bolts that fasten the load sensor to the mount. Tighten the bolts finger tight.
- Step 14. Use a Torque Wrench and tighten the bolts to the torque rating in Table 4. It is a good idea to switch back and forth between each bolt until the torque value has been reached.

BOLT	Grade	Torque
.500 - 20 UNC (M12 8.8)	5	65 Ft/Lbs (90 Nm)

Table 4: Torque Specifications for Load Sensor Bolts

- Step 15. Run the load sensor cable through the channel to the summing box. Bundle up any excess cable and store it in the channel. **DO NOT CUT THE CABLE TO MAKE IT FIT BETTER. *If you cut the cable, you will not get correct readings from the load sensors and it will void your warranty.***
- Step 16. Reconnect the cable wires according to the color code in Step 3 to the correct load sensor connector.

WARNING

LOAD CELL CABLE LENGTH HAS BEEN CALCULATED INTO C2 CALIBRATION DATA. HARDY RECOMMENDS THAT YOU DO NOT CUT YOUR ADVANTAGE LOAD SENSOR CABLE, AS YOUR C2 ACCURACY WILL BE AFFECTED AND THE WARRANTY WILL BE VOIDED.

- Step 17. Reassemble the Summing Box Chassis by replacing the top cover and installing and tightening the 8 hex head screws using the 5.5mm hex wrench or a 5.5mm hex socket. Tighten to 10 in-lbs.

OPTIONAL PIT FRAMES

About Pit Frames

The pit frame optional accessory is a one-piece welded unit with no additional welding required. This accessory is designed for in-floor or 'flush' applications. In general, a hole is cut in the concrete, the pit-frame accessory is installed in the hole, then concrete is poured around and under the frame. Once cured, the scale platform is set into the frame and installation can be completed.

Standard duty frames are available in carbon steel or stainless steel for all the floor scale sizes. The concrete work and frame setting is usually done by a contractor, with a scale technician completing the project by setting and installing the scale.

Hardy Floor Scales

- A soil bearing pressure of at least 1,000 lbs per square foot is required. The corner pier should be designed to support at least two thirds of the total capacity of the scale.
- A 3/4" diameter conduit for the scale interface cable is recommended. The pit frame is arranged with a 1 1/8" diameter hole for a cable exit. Locate the conduit to match the hole location.

Step 1. Place the pit frame in the approximate position it will occupy on the floor. (See Fig. 21)

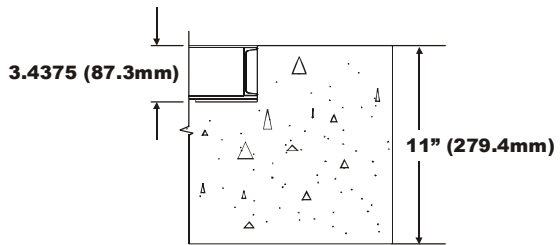

FIG. 21 FOUNDATION FOR THE PIT FRAME

Step 2. Mark out the position of the hole to be made. The hole **MUST** be a minimum of 12" larger than the pit frame on all sides. (See Fig. 22)

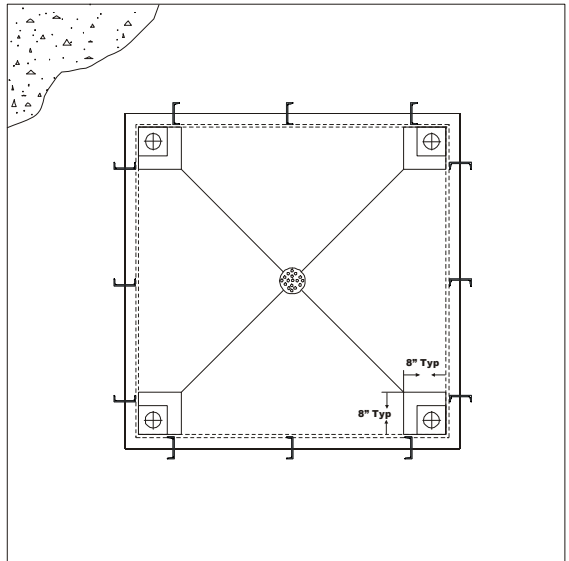

FIG. 22 PIT FRAME DIMENSIONS

Model Number	Platform Size Feet	Platform Size CM	Material
HIFSPF-3030-SS	30in x 30in	76cm x 76cm	Stainless Steel
HIFSPF-3636-SS	36in x 36in	91cm x 91cm	Stainless Steel
HIFSPF-4848-SS	48in x 48in	122cm x 122cm	Stainless Steel
HIFSPF-4860-SS	48in x 60in	122cm x 152cm	Stainless Steel
HIFSPF-4872-SS	48in x 72in	122cm x 183cm	Stainless Steel
HIFSPF6060-SS	60in x 60in	152cm x 152cm	Stainless Steel
HIFSPF6084-SS	60in x 84in	152cm x 213cm	Stainless Steel
HIFSPF7284-SS	72in x 84in	183cm x 244cm	Stainless Steel

Table 5: Pit Frame Stainless Steel/Model Numbers and Dimensions

Hardy Floor Scales

Model Number	Size	Platform Size	Material
HIFSPF-3030-PS	30in x 30in	76cm x 76cm	Painted Carbon Steel
HIFSPF-3636-PS	36in x 36in	91cm x 91cm	Painted Carbon Steel
HIFSPF-4848-PS	48in x 48in	122cm x 122cm	Painted Carbon Steel
HIFSPF-4860-PS	48in x 60in	122cm x 152cm	Painted Carbon Steel
HIFSPF-4872-PS	48in x 72in	122cm x 183cm	Painted Caron Steel
HIFSPF-6060-PS	60in x 60in	152cm x 152cm	Painted Caron Steel
HIFSPF-6084-PS	60in x 84in	152cm x 213cm	Painted Caron Steel
HIFSPF-7284-PS	72in x 84in	183cm x 244cm	Painted Caron Steel

Table 6: Pit Frame Carbon Steel/Model Numbers and Dimensions

- Step 3. Should pit drainage be required, slope the pit floor to an installed drain while maintaining a level area at each corner. (See Fig. 23)

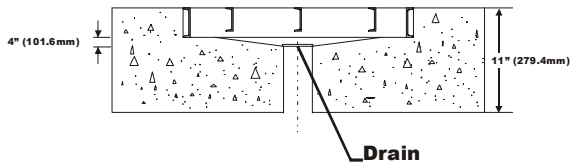

FIG. 23 DRAIN INSTALLATION DIMENSIONS

- Step 4. The drain hole will have to be deep enough to accommodate the pit coping, plus the thickness of the pit floor. (See Fig. 24)

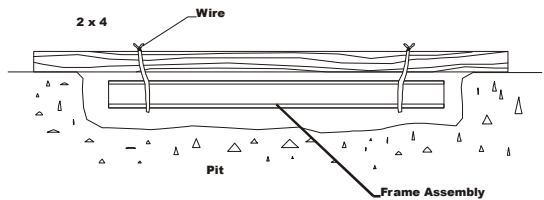

FIG. 24 EXCAVATED PIT AND SUPPORT FOR THE PIT FRAME

- Step 5. Set the frame in the hole supported at about the correct height.
- Step 6. Set two 2 x 4 's on edge (longer than the width of the hole) across the opening. (See Fig. 7)
- Step 7. Use soft wire and make 2 loops by twisting wire around each 2 x 4 and the frame
- Step 8. With the frame supported by the wire and 2 x 4's, use a spirit level to set the frame flush with the surrounding floor, level the frame to within 1/8", corner to corner, side to side and diagonally, and at the correct height by twisting or untwisting the wires. (See Fig. 7)
- Step 9. Concrete specifications:
- At least 6" thickness of concrete is required for pit floor in Non-Hostile applications.
 - At least an 11" concrete floor with a minimum of 3" bottom slope is required if drainage is required for hostile applications. A 4" drain is highly recommended.
 - Make sure the conduit for the scale cable is in place and secured into the frame opening.
 - Pour the concrete around and under the frame ensuring a smooth and level finish. It is recommended that $f = 3500$ psi and 3" to 4" slump concrete be used.
 - If a drain is required, form the pit to place a slope in the pit floor to the drain. (See Fig. 23)

Hardy Floor Scales

- Cure to a minimum of 2000 psi before pulling the interface cable through the conduit.

Step 10. Pull the interface cable through the conduit.

OPTIONAL PORTABILITY KIT

A portability kit is designed to convert a Hardy Floor Scale from a stationary scale to a mobile weighing system for pallets, drums and other large items.

The kit makes it easy to move the scale using a hand jack or standard forklift tines without damaging the scale so you can place it where it is needed. Portability kits are available in both painted carbon steel and stainless steel in standard scale sizes.

OPTIONAL ACCESS RAMPS

Optional access ramps are available in carbon steel or stainless steel. The carbon steel ramps are constructed of A36 carbon steel floor plate with a skid resistant tread. The Stainless Steel ramps are constructed of 304 Stainless Steel, diamond tread floor plate. All ramps are thirty inches (30") (76.2 centimeters) long in the direction of travel and provide a 5° degree incline.

Access Ramp Installation

- Step 1. Determine which side of the floor scale you want the access ramp to be placed. Consider the location of the summing junction box access plate. It cannot be covered by the access ramp. (See Fig. 26) Each carbon steel ramp accessory comes with two integral foot retainer plates and four anchors.
- Step 2. Place the ramp in position, then lift and set the platform feet into the foot retainer plate holes. (See Fig. 25)

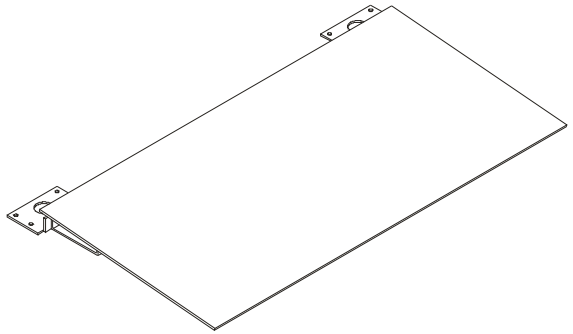

FIG. 25 RAMP WITH RETAINER PLATES

Painted Steel Hardy Model #	Stainless Steel Hardy Model #	Portability Kit		
		feet	cm	Surface
HIFSPK-3636-PS	HIFSPK-3636-SS	36 x 36	76 x 76	Smooth
HIFSPK-4848-PS	HIFSPK-4848-SS	48 x 48	91 x 91	Smooth
HIFSPK-4860-PS	HIFSPK-4860-SS	48 x 60	122 x 152	Smooth
HIFSPK-4872-PS	HIFSPK-4872-SS	48 x 72	122 x 183	Smooth
HIFSPK-6060-PS	HIFSPK-6060-SS	60 x 60	152 x 152	Smooth

Step 3. Dri
l
l
t
h
e
t

two (2) outer holes using a hammer drill.
(See Specifications/Anchor Bolt Holds
above for hole dimensions)

Step 4. Insert the anchor bolts with the nut and
washer already ON. (See Fig. 26)

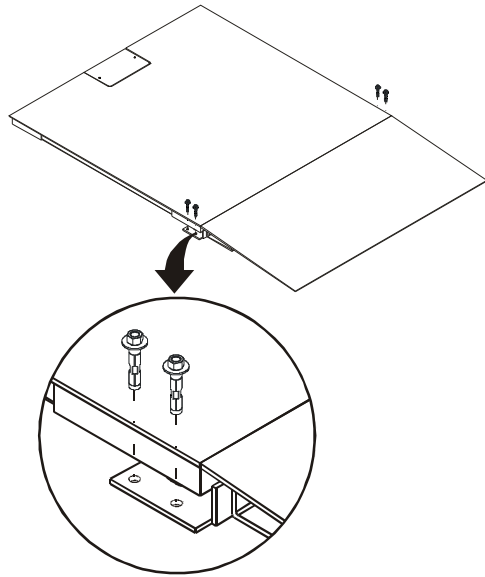

FIG. 26 INSTALLING ANCHORS FOR RAMP

- Step 5. Tap the anchor bolt into the hole then tighten the nuts securely.
- Step 6. Lift the Platform out and away from the foot retainer plate.
- Step 7. Drill the two (2) inner holes using a hammer drill. (See Specifications/Anchor Bolt Holds above for hole dimensions)
- Step 8. Insert the anchor bolts with the nut and washer already ON.
- Step 9. Tap the anchor bolts into the hole then tighten the nuts securely
- Step 10. Note the following:
- If two ramps are installed, NO other foot retainer plates are needed
 - If one ramp is installed then a set of two foot retainer plates are needed.
 - Only two ramps total may be installed on opposite sides of a scale platform.

**OPTIONAL FOOT
RETAINER**

Foot retaining plates are used to keep the scale from sliding or moving when loads are applied. The plates are bolted via anchors at each of the scales feet. (See Fig. 27)

Foot Retainer

Painted Steel	Stainless Steel	Foot Retainer		
Hardy Model #	Hardy Model #	feet	cm	Surface
HIFSBDP-PS	HIFSBDP-SS	n/a	n/a	Smooth

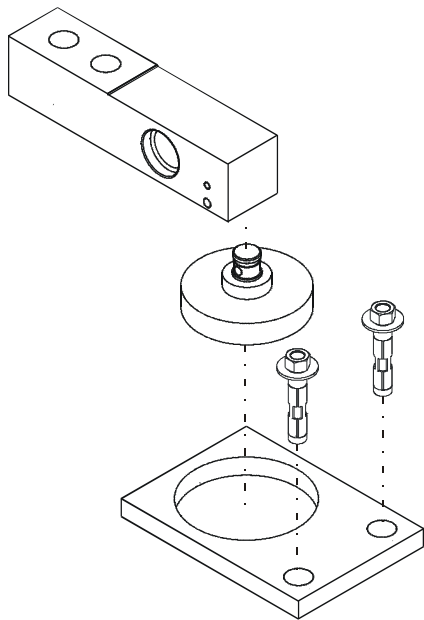

**FIG. 27 FOOT RETAINER PLATES
INSTALLATION**

NOTE:

The platform has been removed for clarity purposes.

**Foot Retainer
Plates Installation**

- Step 1. Place the Floor Scale in position.
- Step 2. Place the foot retainer plate under the foot, plate edge should extend out from under the scale.
- Step 3. Drill two (2) holes using a hammer drill. (See Specifications/Anchor Bolt Holds

Hardy Floor Scales

above for hole dimensions) Insert anchor bolts with the nut and washer already attached.

Step 4. Tap the anchor bolts into the hole then tighten the nuts securely.

Step 5. Repeat this process for each plate used in your installation.

NOTE:

If ramps are NOT installed and foot retainer plates are needed, then a set of four (4) foot retainer plates are required.

OPTIONAL BUMPER GUARDS

Bumper guards are designed to help protect the platform from direct hits from forklift traffic. The guards are slightly higher than the scale and will help deflect the forks.

Painted Steel	Stainless Steel	Bumper Guard Size		
Hardy Model #	Hardy Model #	inches	cm	Surface
HIFSBG-30-PS	HIFSBG-30-SS	30	76	Smooth
HIFSBG-36-PS	HIFSBG-36-SS	36	91	Smooth
HIFSBG-48-PS	HIFSBG-48-SS	48	122	Smooth
HIFSBG-60-PS	HIFSBG-60-SS	60	152	Smooth
HIFSBG-72-PS	HIFSBG-72-SS	72	183	Smooth
HIFSBG-84-PS	HIFSBG-84-SS	84	213	Smooth
HIFSBG-96-PS	n/a	96	244	Smooth
-1MC, -2MC	-1MC, -2MC	EA Mitered Corner		Smooth
-2RP	-2RP	Set of 2 Retaining Plates		Smooth

Installing Bumper Guards

Step 1. Place the bumper guard so it will protect the platform from non-scale traffic and not touch or interfere with the platform's movement. (See Figs. 28 & 29)

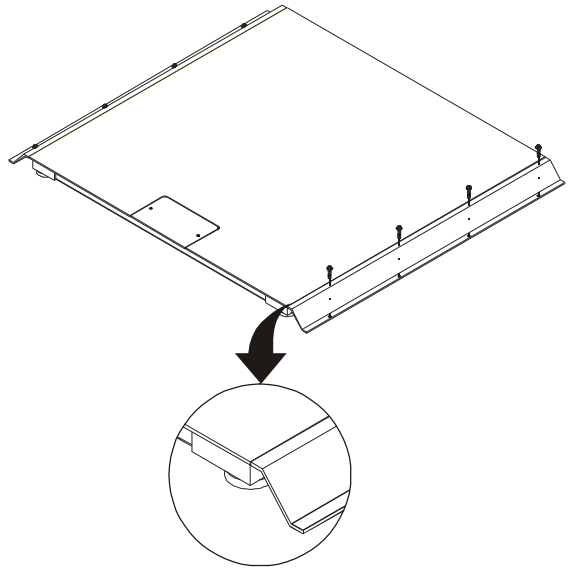

FIG. 28 BUMPER GUARD/GAP REQUIREMENT

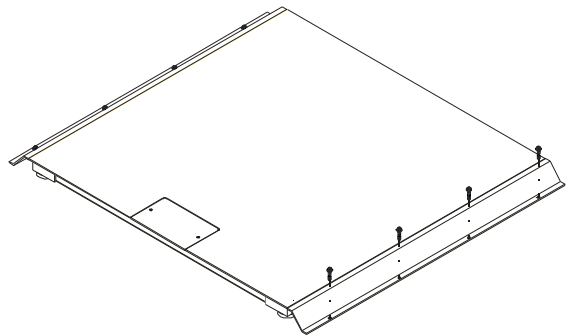

FIG. 29 BUMPER GUARD/INSTALLATION

- Step 2. Drill the holes using a hammer drill. (See Specifications/Anchor Bolt Holds above for hole dimensions)
- Step 3. Insert the anchor bolts with the nut and washer already installed.

Hardy Floor Scales

- Step 4. Tap the anchor bolts into the hole then tighten the nuts securely.

Optional Indicator Column

Many Floor Scale installations require the weight to be displayed DIRECTLY at the scale. An Indicator column allows the site to mount an instrument directly by the scale for ease of reading.

Hardy Floor Scales feature an optional 4 ft. Indicator column for mounting a Hardy controller or weight processor directly above the floor scale.

NOTE:

To purchase optional equipment for the Hardy Floor Scales, contact your local Hardy Representative or Hardy Process Solutions Service Center.

TROUBLESHOOTING

1. Check all cables to be sure that they have no cracks, cuts or crimps. Check for broken cables.
2. Check for loose fitting connections.
3. Look for the presence of moisture at all connections and under or near the summing junction box cover.
4. Look for structural changes in the platform scale and supporting structures.
5. Periodically check to see if the platform is level.

Problem:

Scale does not respond when a weight is placed on the platform.

Cause #1:

Packing material or debris wedged or built up underneath the platform

Cause #2:

Platform scale is not wired correctly to the weighing instrument.

Cause #3:

Weigh Process Controller Malfunction

Remedies:

- Carefully lift the platform high enough to safely remove the built up debris.
- Check for loose connections or broken wires.
- Check the wiring color code to be sure that the wires are routed correctly. If they are not

wired correctly change the wiring until it is correct.

- Check the Weighing Instrument Manual for trouble shooting instructions.

Problem: Scale indication is not linear.

Cause #1: Packing material or debris wedged or built up underneath the platform

Remedy #1:

- Carefully lift the platform high enough to

Indicator Column

Painted Steel	Stainless Steel	Indicator Column		
Hardy Model #	Hardy Model #	inhes	cm	Surface
HIFSI-48-PS	HIFSI-48-SS	48 tall	91 cm tall	Smooth

safely remove the built up debris.

- Check for loose connections or broken wires.

Cause #2: Weighing instrument or floor scale is not calibrated.

Remedy #2:

- Re-calibrate either the weight instrument or the floor scale or both.
- Check for corrosion on the electrical connections.

Problem: The scale reading drifts or is erratic.

Cause #1: Corrosion or moisture in the electrical connections.

Remedy #1:

- Check to see that the summing junction box is tightly fastened.
- Check to see that the gaskets and seals are not cracked or damaged.
- Remove the wires and clean any corrosion from the connectors and exposed wire.
- For high humidity areas, place a desiccant packet in the summing junction card enclosure.

Cause#2: High voltage wires close to the load sensor cable.

Remedy #2: Move the high voltage wires away from the load sensor cable.

Hardy Floor Scales

Cause #3: Instrument or floor scale improperly grounded (i.e. one or both not connected to earth ground).

Remedy #3: Make sure that the weigh instrument and the floor scale platform cover are both connected to earth ground.

Cause #4: High static electricity present.

Remedy #4: Install a ground strap from the floor scale platform cover to earth ground.

WARNING

DO NOT CONNECT THE GROUND STRAP NEAR OR ON THE LOAD SENSORS. THEY ARE GROUNDED THROUGH THE SUMMING JUNCTION BOX. TO DO SO WILL DAMAGE THE LOAD SENSORS.

INSTRUMENTATION INTERFACE CABLE COLOR CODES

-EXCITATION	RED
+SENSE	BLUE
+SIGNAL	GREEN
-SIGNAL	WHITE
-SENSE	BROWN
-EXCITATION	BLACK
+C2	GREY
-C2	VIOLET
SHIELD	ORANGE

Numerics

304 stainless steel platform 1-5

A

About Pit Frames 1-25

acceptable tolerance 1-14

Access Ramp Installation 1-30

Accessories 1-3

active elements 1-1

Allen Bradley module manual 1-12

Attach a chain 1-4

B

Blind Hole Load Introduction technology 1-1

Block the floor scale 1-23

Bolt-Down Plates Installation 1-33

Bundle 1-25

C

C2 Certified Summing Card Interface Cable 1-12

C2® Certified cable 1-11

C2® Second Generation Calibration 1-12

C2® Second Generation Calibration system 1-1

Cable Length 1-3

CALIBRATION 1-11

chain 1-23

closed eye bolts 1-23

Color code wires 1-22

commercial accuracy 1-1

COMPONENT DESCRIPTIONS 1-5

conduit 1-26

cord grip nut 1-23

corner to corner 1-6

Cure 1-30

D

diamond tread floor plate 1-30

Hardy Floor Scales

direct hits 1-34

E

end to end 1-6

Endloading 1-2

Excitation 1-2

eyebolts 1-4

F

flat head machine screws 1-17

FLOOR SCALE INSTALLATION 1-8

Foot Elastomer 1-3

forklift 1-4

forklift traffic 1-34

G

Grade Level 1-3

H

hammer drill 1-31

Hardy Floor Scales 1-1

Hardy Instruments Service Center 1-7

Hardy weight or rate controller manuals 1-12

hostile applications 1-29

I

increase the height 1-10

inner holes 1-32

INSTALLING A LOAD SENSOR 1-21

Installing the Leveling Feet 1-19

instrument/indicator 1-18

INSTRUMENTATION INTERFACE CABLE COLOR CODES 1-38

INTEGRATED TECHNICIAN™ (Option) 1-6

L

level readings 1-10

Leveling Feet 1-6

load forces 1-1
load sensor bolts 1-24
Load Sensors 1-6
loops 1-29

M

Material Substitution 1-13
Maximum Overload 1-2
Mild Steel Deck, Painted 1-14
mild steel ramp 1-30
MODEL CODE BREAKDOWN 1-14

N

Natural Rubber 1-3
NEMA 4X 1-3
NEMA Rating 1-3
Non-Hostile applications 1-29
non-level floor 1-1
non-scale traffic 1-34
nylon strap 1-4
nylon strapping 1-23

O

Optional Bolt Down Plates 1-11
OPTIONAL BOLT-DOWN PLATES 1-33
OPTIONAL BUMPER GUARDS 1-34
OPTIONAL PIT FRAMES 1-25

P

Paint 1-3
phillips screwdriver 1-17
pit coping 1-28
pit drainage 1-28
pit floor 1-28
pit mounting surface 1-1
Platform Height 1-1
Platform Material 1-1

Hardy Floor Scales

Position #1 1-13

position #2 1-13

position #3 1-13

position #4 1-13

Pre-Calibration Procedures 1-11

Precautions 1-7

Proper drainage 1-7

R

rated lifting capacity 1-4

repeatable weighments 1-1

Requirements 1-12

S

safety precautions 1-4

scale platform 1-25

SCALE VERIFICATION 1-13

SITE PREPARATION 1-6

Skid Resistant 1-30

slotted head screw driver 1-22

socket wrench 1-23

soft wire 1-29

soil bearing pressure 1-26

spirit level 1-9

Stainless Steel ramps 1-30

Steel 1-3

Steel Plate Platform 1-5

summing card 1-21

Summing Junction Card Assembly 1-5

T

Temperature Effect 1-3

Temperature Range 1-3

Test Criteria 1-4

Test weight calibration 1-12

Test Weight Calibration (Hard Cal) 1-12

Torque Wrench 1-24

Total Error 1-2

TROUBLESHOOTING 1-36

U

UNPACKING 1-4

W

welding 1-7

Hardy Floor Scales